

DRAWING NUMBER **OMW-12064**

REVISION	DESCRIPTION OF CHANGE	DATE	ECO NUMBER	APPROVED BY
PRE-01	INITIAL DESIGN	04/04/2018	-	

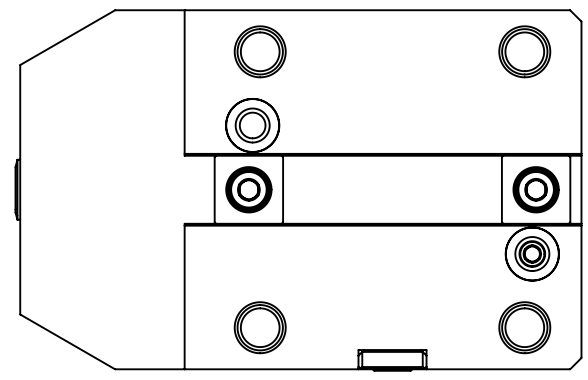
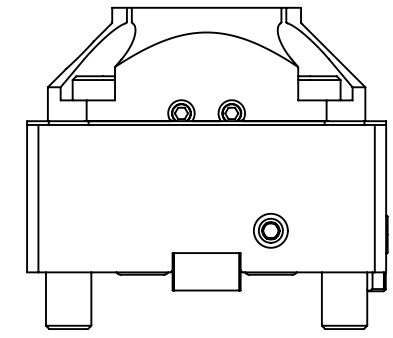
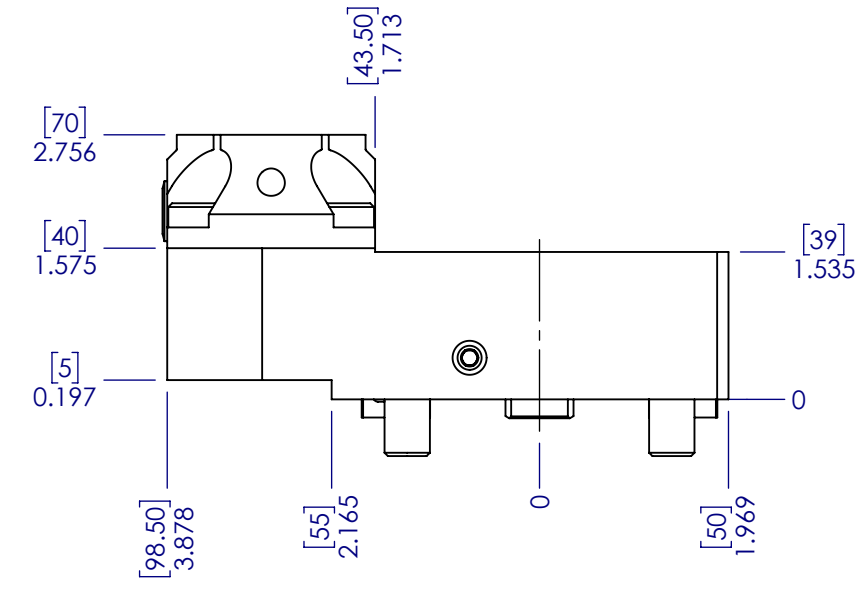
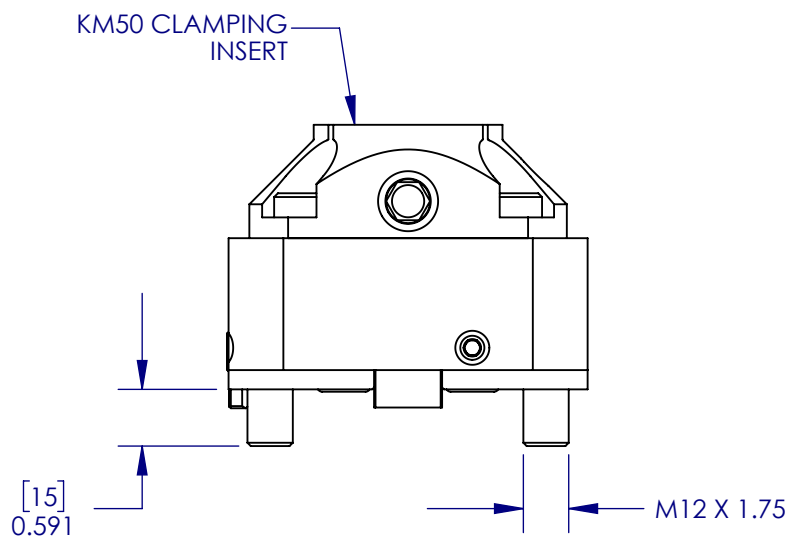
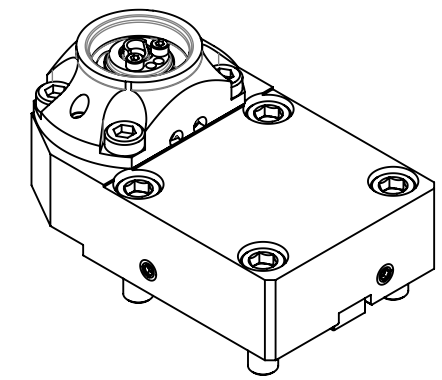
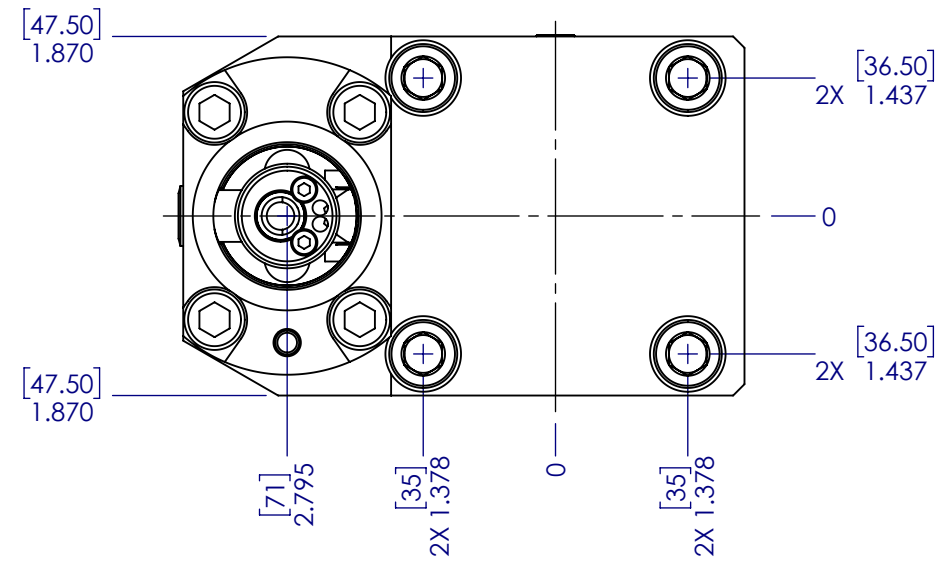

RedLine	DRAWING NUMBER OMW-12064		
	DESCRIPTION BMT KM50 TTH SKT250		
PART NUMBER RB65ODKM50S			
DRAWN BY	DATE 04/04/2018	DESIGN STATUS PRE-PRODUCTION	REV. PRE-01
PRIOR DRAWING NUMBERS N/A	WEIGHT N/A	PROCESS STATE FINISHED ASSEMBLY	SCALE 1:2
SIZE B			SHEET 1 OF 1